



Air tank (related products)

AT Series

JIS symbol



Features

Air tank directly connected to air booster ABP-12 with compact body.

Specifications

Descriptions	AT
Working fluid	Compressed air
Max. working pressure MPa	0.99
Hydraulic test pressure MPa	1.5
Ambient temperature range °C	0 to 50 (no freezing)
Capacity m ³	0.024
Port size	Rc1/2
Weight kg	17.5

Note: O ring, hexagon head bolt and spring washer are attached to install air booster.

How to order

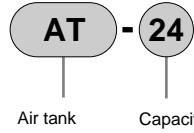

● Part model no.

AT-K1 (O ring, hexagon head bolt, spring washer)

Dimensions

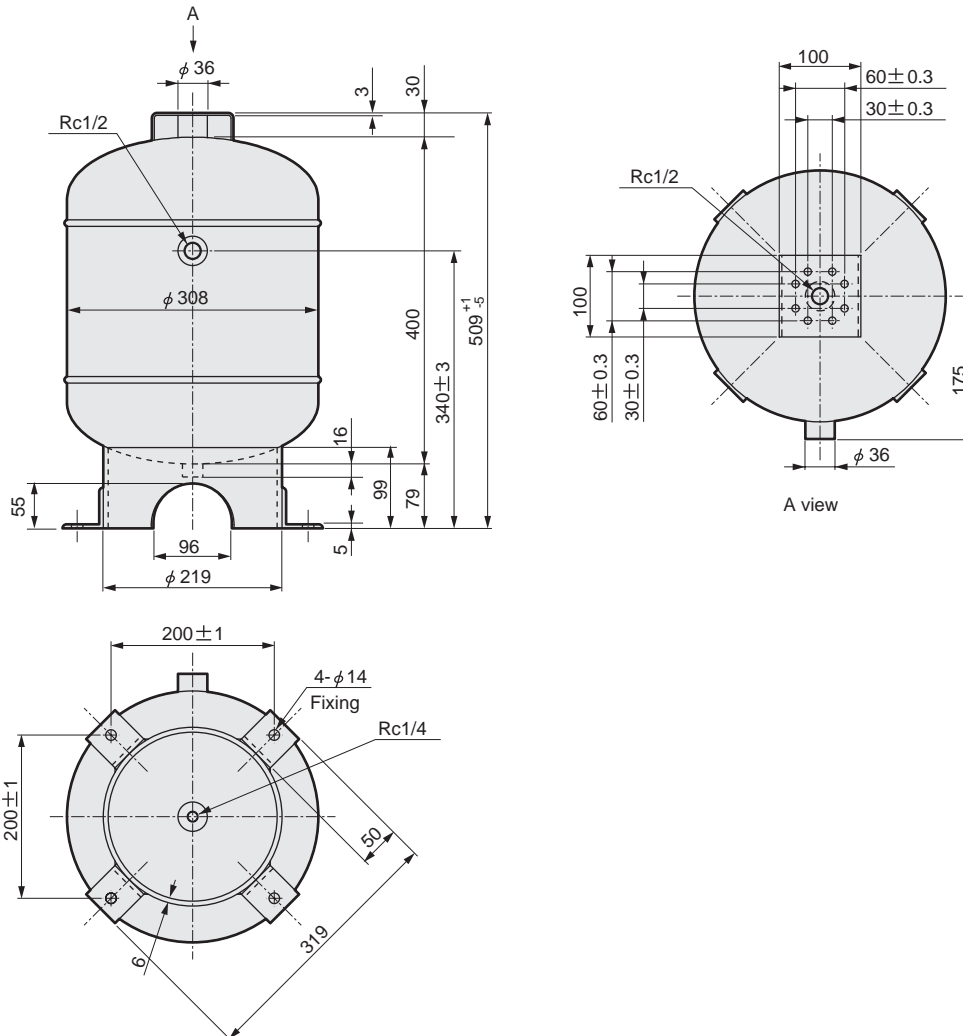

Refrigerating type dryer
Desiccant type dryer
High polymer membrane dryer
Air filter
Auto. drain / others
F.R.L. (Module unit)
F.R.L. (Separate)
Compact F.R.
Precise regulator
F.R.L. (Related products)
Clean F.R.
Electro pneumatic regulator
Air booster
Speed control valve
Silencer
Check valve / others
Joint / tube
Vacuum filter
Vacuum regulator
Suction plate
Magnetic spring buffer
Mechanical pressure SW
Electronic pressure SW
Contact / close contact conf. SW
Air sensor
Pressure SW for coolant
Small flow sensor
Small flow controller
Flow sensor for air
Flow sensor for water
Total air system
Total air system (Gamma)

Ending

Air booster